

ADVANTEST

# R3755A/3760

Making a personal computer a vector network analyzer

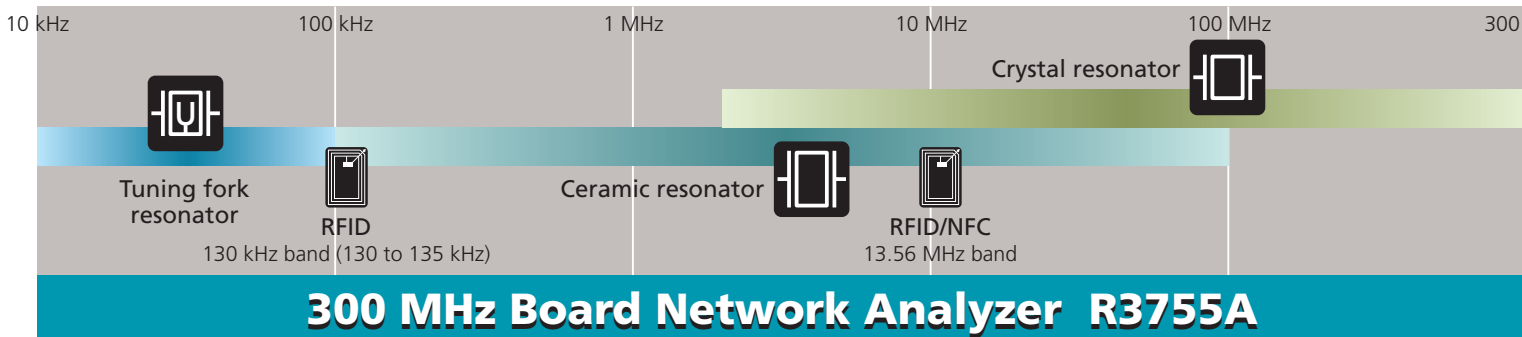



**Compact size, light weight, low power consumption of less than 15 W, and with the capacity to drive up to eight units in parallel.**

The R3755A network analyzer evaluates the frequency characteristics of electronic components, such as the crystal resonator and ceramic resonator used in a broad range of electronic equipment, as well as antennas for receiving/transmitting wireless signals.

### R3755A Key Specifications

#### Measurement functions

Measurement channels: 4  
Measurement parameters: A/R (R channel is connected internally)

#### Signal source characteristics (25°C ± 5°C, calibration cycle one year)

**Frequency characteristics**  
Range: 10 kHz to 300 MHz  
Resolution: 1 mHz  
Accuracy: ±20 ppm (OPT.20: ±1 ppm)

**Output characteristics**  
Range: 10 kHz to 1 MHz: 0 to -30 dBm  
1 to 300 MHz: +18 to -43 dBm 0.1 dB resolution  
Range set-up: Start/Stop, or Center/Span  
Sweep type: Arbitrary sweep of specified segment (Frequency, Output level, RBW, Point, Settling time)

Sweep speed: Maximum 50 μsec/point (RBW 15 kHz)  
Measurement point: Maximum 1601 points (segment)  
Output port: SMA (female) 50Ω connector

#### Receiving section characteristics (25°C ± 5°C, calibration cycle one year)

**Input characteristics**  
Input: SMA (female) 50Ω connector  
Frequency range: Same as the signal source characteristics  
Average noise level: -70 dBm (RBW: 1 kHz)  
Resolution bandwidth: 10 Hz to 15 kHz (1, 1.5, 2, 3, 4, 5, or 7 steps)  
Error correction functions: Normalize, Trans Full Call (Full Call: Open, Short, Load)

#### Connections to external devices

Parallel I/O: 8-bit output (C-MOS), 4-bit input (C-MOS)

#### General specifications

Loadable PC<sup>1)</sup>  
Expansion-slot<sup>2)</sup>: PC which carries 1 PCI slot (32 Bit, 5 V, half-size)  
OS: Windows 10 (64 bit), 7 (32/64 bit), Vista (32 bit), XP (32 bit)

Development environment of application: Microsoft Visual Basic 2008 or Visual C++2008  
Microsoft Visual Basic 6.0 or Visual C++6.0  
Power supply: +5 VDC (5W), +3.3 VDC (5W), +12 VDC (1W), -12 VDC (1W) (typical)

Power consumption: 15 W or less  
External dimensions: Approx. 190 (W) x 126 (H) x 20 (D) mm  
Mass: 1 kg or less

- 1) Depending on the specifications of the PC to be used, it may not operate.
- 2) Please keep the ambient air temperature (temperature in the PC) of this device equipped to the PC expansion slot from exceeding +55 degree C.

Microsoft, Windows and Visual Basic are registered trademarks of Microsoft Corporation in the United States and other countries.



Measurement example with R3755A sample software

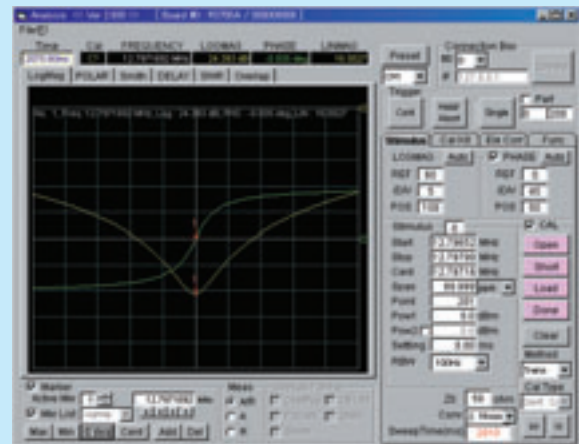

Example of oscillation characteristics measurement for crystal resonator

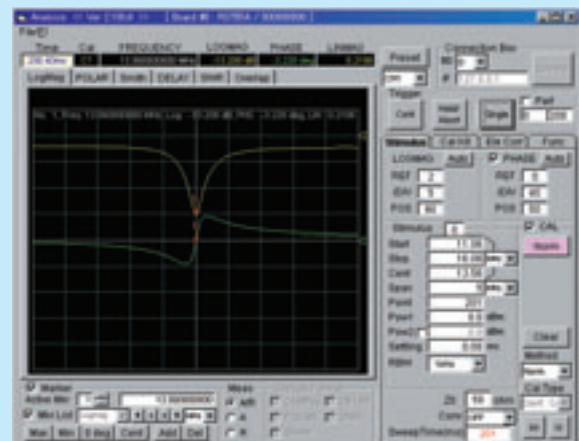

Example of oscillation frequency measurement for RFID

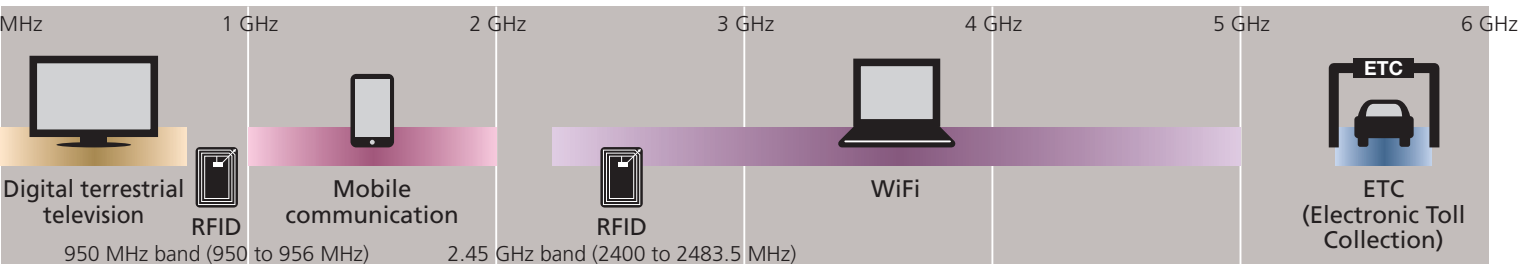

## 6 GHz Board Network Analyzer R3760



**Compact size, light weight, low power consumption of less than 20 W, and with the capacity to drive up to eight units in parallel.**

The R3760 network analyzer, low in cost and with a space-saving design, measures and evaluates the frequency characteristics of receiving/transmitting antennas and filters, which are used for wireless communications.

### R3760 Key Specifications

#### Measurement functions

Measurement channels: 4  
Measurement parameters: Reflection (S11), Transmission (S21)

#### Signal source characteristics (25°C ± 5°C, calibration cycle one year)

Frequency characteristics  
Range: S11/S21: 300 MHz to 6 GHz  
Resolution: 10 kHz  
Accuracy: ±50 ppm (OPT.20: ±1 ppm stability)

Output characteristics  
Range: ≤3 GHz: 0 to -10 dBm  
>3 GHz: -5 to -10 dBm 0.1 dB resolution  
Range set-up: Start/Stop, or Center/Span  
Sweep type: Arbitrary sweep of specified segment (Frequency, Output level, RBW, Point, Settling time)

Sweep speed: Maximum 300 µsec/point  
Measurement point: Maximum 1601 points (segment)  
Output port: SMA (female) 50Ω connector

#### Receiving section characteristics (25°C ± 5°C, calibration cycle one year)

Input characteristics  
Input: SMA (female) 50Ω connector  
Frequency range: Same as the signal source characteristics  
Average noise level: -70 dBm (RBW: 1 kHz)  
Resolution bandwidth: 10 Hz to 15 kHz (1, 1.5, 2, 3, 4, 5, or 7 steps)  
Error correction functions: 1-Port Full Cal, Normalize, Trans Full Cal

#### Connections to external devices

Parallel I/O: 8-bit output (C-MOS), 4-bit input (C-MOS)

#### General specifications

Loadable PC<sup>1)</sup>  
Expansion-slot<sup>2)</sup>: PC which carries two PCI slots (32 Bit, 5V, half-size)

OS: Windows 10 Pro (64 bit), 7 (32/64 bit), Vista (32 bit), XP (32 bit)

Development environment of application: WindowsXP sp2 MS VB Net Framework 2.0 or more  
Microsoft Visual Basic 6.0 or Visual C++6.0

Power supply: +5 VDC (7W), +3.3 VDC (10W), +12 VDC (1W), -12 VDC (1W) (typical)

Power consumption: 20 W or less  
External dimensions: Approx. 190 (W) x 126 (H) x 42 (D) mm  
Mass: 1 kg or less

- 1) Depending on the specifications of the PC to be used, it may not operate.
- 2) Please keep the ambient air temperature (temperature in the PC) of this device equipped to the PC expansion slot from exceeding +55 degree C.

Please refer to product manual for complete system specifications.  
Specifications may change without notification.

Measurement example with R3760 sample software

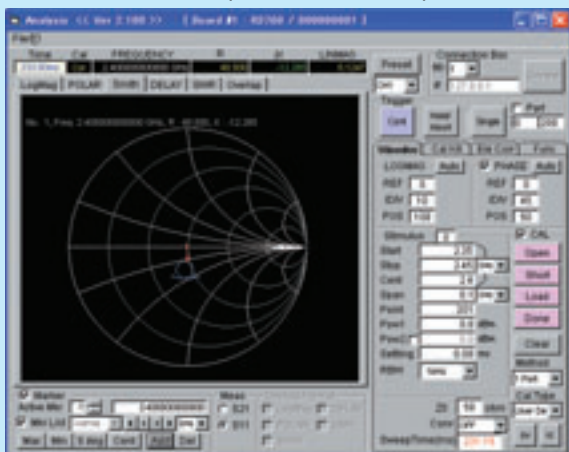

Example of impedance measurement for antenna

Use by mounting in PC

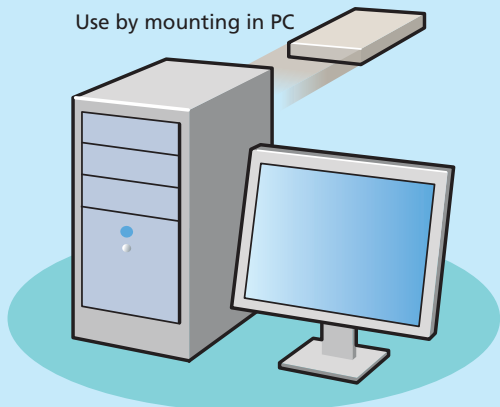

For more information on the calibration kit required for impedance measurement, please contact our office.

## Optional Accessories for Expanding Applications of Board Network Analyzer

### ● 4-Port Adapter A170009

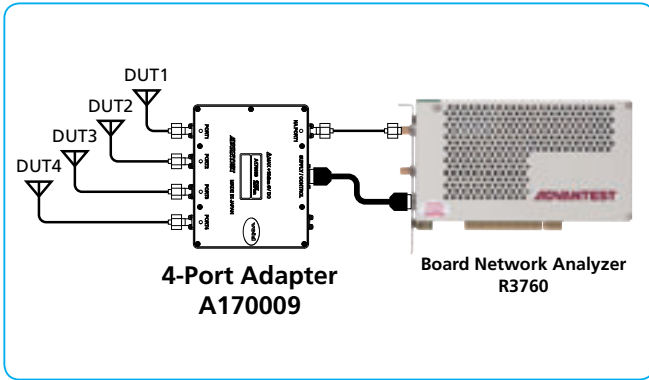

#### A170009 Key Specifications

##### Input/Output port

Port numbers:	5
Switchable path	
On State1:	Path between NA PORT1 - PORT1 is On
On State2:	Path between NA PORT1 - PORT2 is On
On State3:	Path between NA PORT1 - PORT3 is On
On State4:	Path between NA PORT1 - PORT4 is On
Connector:	SMA (female) 50Ω connector

##### Input/Output signal characteristics (25°C ± 5°C)

Frequency characteristics range:	300 MHz to 6 GHz
Input characteristics	
Maximum input level:	0 dBm
Absolute maximum input level:	+15 dBm, 0 VDC
Insertion loss	
Between On State path:	300 MHz to 500 MHz: <2.5 dB
	500 MHz to 3 GHz: <4.0 dB
	3 GHz to 6 GHz: <5.5 dB

##### General specifications

Power supply:	+5 VDC (0.5 W) The power supply is supplied from R3760 by accessory cable for parallel I/O.
Power consumption:	0.5 W or less
Dimensions:	Approx. 132 (W) x 26 (H) x 126 (D) mm
Mass:	1 kg or less

<b>Accessories</b>	DC power and Control cable	1
	RF cable	1
	Application software (provide in CD-ROM for the operation manual)	1

### ● Forward/Reverse Adapter A170010

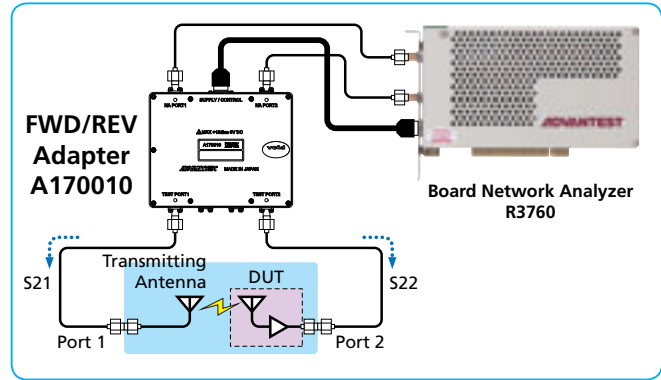

#### A170010 Key Specifications

##### Input/Output port

Port numbers:	4
Switchable path	
On State1:	Path between NA PORT1 - TEST PORT1, and path between NA PORT2 - PORT2 are On
On State2:	Path between NA PORT1 - TEST PORT2, and path between NA PORT2 - PORT1 are On
Connector:	SMA (female) 50Ω connector

##### Input/Output signal characteristics (25°C ± 5°C)

Frequency characteristics range:	300 MHz to 6 GHz
Input characteristics	
Maximum input level:	0 dBm
Absolute maximum input level:	+15 dBm, 0 VDC
Insertion loss	
Between On State path:	300 MHz to 500 MHz: <2.5 dB
	500 MHz to 3 GHz: <4.0 dB
	3 GHz to 6 GHz: <5.5 dB

##### General specifications

Power supply:	+5 VDC (0.5 W) The power supply is supplied from R3760 by accessory cable for parallel I/O.
Power consumption:	0.5 W or less
Dimensions:	Approx. 132 (W) x 26 (H) x 126 (D) mm
Mass:	1 kg or less

<b>Accessories</b>	DC power and Control cable	1
	RF cable	2
	Application software (provide in CD-ROM for the operation manual)	1

**ADVANTEST**<sup>®</sup>

<https://www.advantest.com/>

ADVANTEST CORPORATION  
Shin-Marunouchi Center Building, 1-6-2 Marunouchi, Chiyoda-ku, Tokyo 100-0005, Japan Phone: +81-3-3214-7500